

## Lightem 8.5G SFP+ Transceiver 15km LCS800S13150

### FEATURE

- Supports 8.5Gbps bit rates
- Up to 15km transmission on SMF
- DFB Laser and PIN receiver
- Metal enclosure, for lower EMI
- 2-wire interface with integrated Digital Diagnostic monitoring
- Hot-pluggable SFP+ footprint
- Specifications compliant with SFF 8472
- Compliant with SFP+ MSA with LC connector
- Single 3.3V power supply
- Case operating temperature range: 0°C to 70°C
- Power dissipation < 1.0W



### APPLICATIONS

- Multi-rate 8x / 4x / 2x Fiber Channel

### STANDARD

- Compliance with Fiber Channel FC-PI-4 800-SM-LC-L
- Compliant with 8G, 4G and, 2G Fiber Channel
- RoHS Compliant.

### ABSOLUTE MAXIMUM RATINGS

Parameter	Symbol	Min.	Typ.	Max.	Unit	Note
Storage Temperature	Ts	-40	-	85	°C	
Relative Humidity	RH	5	-	95	%	
Power Supply Voltage	VCC	-0.3	-	+4	V	
Signal Input Voltage		Vcc-0.3	-	Vcc+0.3	V	

### RECOMMENDED OPERATING CONDITIONS

Parameter	Symbol	Min.	Typ.	Max.	Unit	Note
Case Operating Temperature	Tcase	0		+70	°C	Without air flow
Power Supply Voltage	VCC	3.14	3.3	3.47	V	
Power Supply Current	ICC	-		300	mA	
Data Rate	BR		8.5		Gbps	
Transmission Distance	TD		-	15	km	
Coupled fiber			Single mode fiber			9/125um SMF

# TELECOM/DATACOM SYSTEM

## ELECTRICAL CHARACTERISTICS

Parameter	Symbol	Min	Typ	Max	Unit	Note
Supply Voltage	Vcc	3.14	3.3	3.46	V	
Supply Current	Icc			300	mA	
<b>Transmitter</b>						
Input differential impedance	RIN		100		$\Omega$	1
Single ended data input swing	Vin, pp	180		700	mV	
Transmit disable voltage	VD	Vcc-1.3		Vcc	V	
Transmit enable voltage	VEN	Vee		Vee+0.8	V	2
<b>Receiver</b>						
Differential data output swing	Vout, pp	300		850	mV	3
LOS Fault	VLOS fault	Vcc-1.3		VccHost	V	4
LOS Normal	VLOS norm	Vee		Vee+0.8	V	4

### Notes:

1. Connected directly to TX data input pins. AC coupled thereafter.
2. Or open circuit.
3. Into 100 ohms differential termination.
4. Loss Of Signal is LVTTL. Logic 0 indicates normal operation; logic 1 indicates no signal detected.

## OPTICAL CHARACTERISTICS

Parameter	Symbol	Min	Typ	Max	Unit	Note
<b>Transmitter</b>						
Output Opt. Power	POUT	-6		-0.5	dBm	1
Optical Wavelength	$\lambda_c$	1260	1310	1355	nm	
Spectrum Band Width (-20dB)	$\sigma$			1.0	nm	
Optical Extinction Ratio	ER	3.5			dB	
Output Eye Mask		Compliant with FC-PI-4				
<b>Receiver</b>						
Receiver Sensitivity	Psens			-14.4	dBm	2
Input Saturation Power (Overload)	Psat	0.5			dBm	
Wavelength Range	$\lambda_c$	1270		1610	nm	
LOS De-Assert	LOSD			-17	dBm	
LOS Assert	LOSA	-30			dBm	
LOS Hysteresis		0.5	1.0		dB	

### Notes:

1. Class 1 Laser Safety per FDA/CDRH and IEC-825-1 regulations.
2. Measured with a PRBS 231-1 test pattern, @8.5Gb/s, BER<10<sup>-12</sup>.

# TELECOM/DATACOM SYSTEM

## PIN DESCRIPTION

Pin	Symbol	Name /Description	NOTE
1	VEET	Transmitter Ground (Common with Receiver Ground)	1
2	T FAULT	Transmitter Fault.	2
3	T DIS	Transmitter Disable. Laser output disabled on high or open.	3
4	SDA	2-wire Serial Interface Data Line	4
5	SCL	2-wire Serial Interface Clock Line	4
6	MOD_ABS	Module Absent. Grounded within the module	4
7	RS0	Rate Select 0	5
8	LOS	Loss of Signal indication. Logic 0 indicates normal operation.	6
9	RS1	No connection required	1
10	VEER	Receiver Ground (Common with Transmitter Ground)	1
11	VEER	Receiver Ground (Common with Transmitter Ground)	1
12	RD-	Receiver Inverted DATA out. AC Coupled	
13	RD+	Receiver Non-inverted DATA out. AC Coupled	
14	VEER	Receiver Ground (Common with Transmitter Ground)	1
15	VCCR	Receiver Power Supply	
16	VCCT	Transmitter Power Supply	
17	VEET	Transmitter Ground (Common with Receiver Ground)	1
18	TD+	Transmitter Non-Inverted DATA in. AC Coupled.	
19	TD-	Transmitter Inverted DATA in. AC Coupled.	
20	VEET	Transmitter Ground (Common with Receiver Ground)	1

### Notes:

- 1.Circuit ground is internally isolated from chassis ground.
- 2.TFAULT is an open collector/drain output, which should be pulled up with a 4.7k – 10k Ohms resistor on the host board if intended for use. Pull up voltage should be between 2.0V to Vcc + 0.3V.A high output indicates a transmitter fault caused by either the TX bias current or the TX output power exceeding the preset alarm thresholds. A low output indicates normal operation. In the low state, the output is pulled to <0.8V.
- 3.Laser output disabled on TDIS >2.0V or open, enabled on TDIS<0.8V.
- 4.Should be pulled up with 4.7k $\Omega$ - 10k $\Omega$  host board to a voltage between 2.0V and 3.6V. MOD\_ABS pulls line low to indicate module is plugged in.
- 5.Internally pulled down per SFF-8431 Rev 4.1.
- 6.LOS is open collector output. It should be pulled up with 4.7k $\Omega$  – 10k $\Omega$  on host board to a voltage between 2.0V and 3.6V. Logic 0 indicates normal operation; logic 1 indicates loss of signal.

# TELECOM/DATACOM SYSTEM

## PIN OUT OF CONNECTOR BLACK ON HOST BOARD

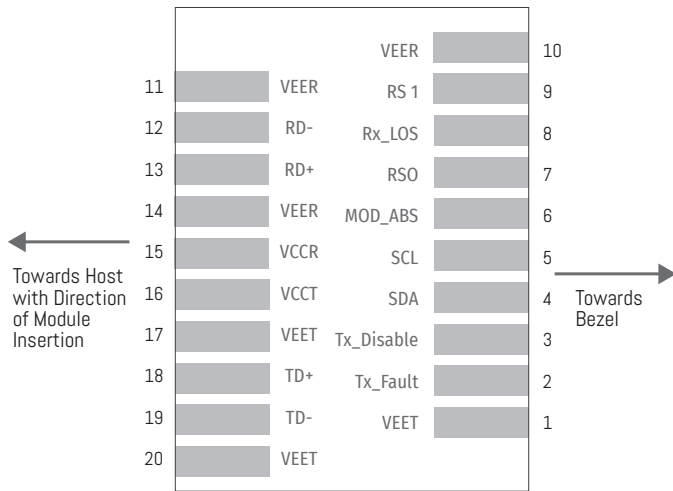

## MECHANICAL DIMENSIONS

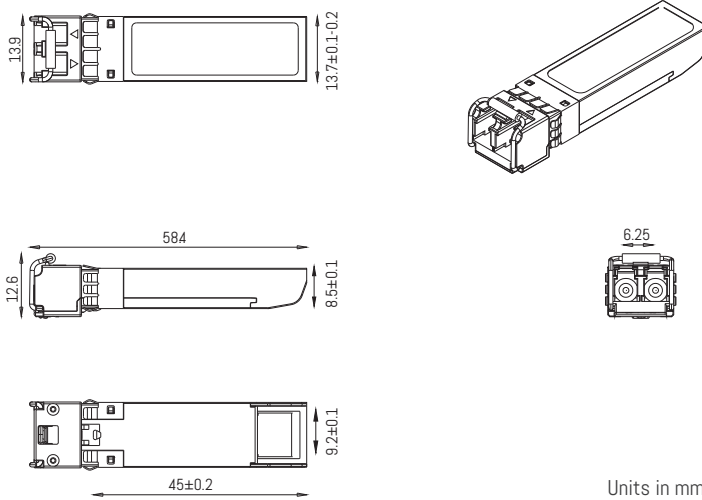

## ORDERING INFORMATION

PN	Descriptions
LCS800S13150	Lightem 8.5G SFP+ Transceiver 10km