

TELECOM/DATACOM SYSTEM

Lightem 10G DWDM SFP+ Transceiver 80km

The LSFP+SDW050xxx80 transceivers include an APD receiver and temperature stabilized EML transmitter. Digital diagnostic functions are available via an I2C. This module is designed for single mode fiber and operates at a nominal wavelength of 50GHz ITU Grid, C Band DWDM wavelength.

FEATURES

- Up to 11.3Gbps Data Links
- Up to 80km transmission on SMF
- DWDM EML Laser and APD receiver
- Metal enclosure, for lower EMI
- 2-wire interface for management
- Hot-pluggable SFP+ footprint
- Specifications compliant with SFF 8472
- Compliant with SFP+ MSA with LC connector
- Single 3.3V power supply
- Case operating temperature range: 0°C to 70°C
- Power dissipation < 1.5W



DIGITAL DIAGNOSTIC FUNCTIONS

LSFP+SDW050xxx80 transceivers support the 2-wire serial communication protocol as defined in the SFP+ MSA. The standard SFP serial ID provides access to identification information that describes the transceiver's capabilities, standard interfaces, manufacturer, and other information. Additionally, XGIGA SFP+ transceivers provide a unique enhanced digital diagnostic monitoring interface, which allows real-time access to device operating parameters such as transceiver temperature, laser bias current, transmitted optical power, received optical power and transceiver supply voltage. It also defines a sophisticated system of alarm and warning flags, which alerts end-users when particular operating parameters are outside of a factory set normal range. The SFP+ MSA defines a 256-byte memory map in EEPROM that is accessible over a 2-wire serial interface at the 8 bit address 1010000X (A0h). The digital diagnostic monitoring interface makes use of the 8 bit address 1010001X (A2h), so the originally defined serial ID memory map remains unchanged. The operating and diagnostics information is monitored and reported by a Digital Diagnostics Transceiver Controller (DDTC) inside the transceiver, which is accessed through a 2-wire serial interface. When the serial protocol is activated, the serial clock signal (SCL, Mod Def 1) is generated by the host. The positive edge clocks data into the SFP transceiver into those segments of the E2PROM that are not write-protected. The negative edge clocks data from the SFP transceiver. The serial data signal (SDA, Mod Def 2) is bi-directional for serial data transfer. The host uses SDA in conjunction with SCL to mark the start and end of serial protocol activation. The memories are organized as a series of 8-bit data words that can be addressed individually or sequentially.

APPLICATIONS

- 10G Ethernet
- 10G SONET/SDH, OTU2/2e and 10G FC

STANDARD

- Compliant to SFF-8431
- RoHS Compliant

ABSOLUTE MAXIMUM RATINGS

Parameter	Symbol	Min.	Typ.	Max.	Unit	Note
Storage Temperature	Ts	-40	-	85	°C	
Relative Humidity	RH	5	-	95	%	
Power Supply Voltage	VCC	-0.3	-	+4	V	
Signal Input Voltage		Vcc-0.3	-	Vcc+0.3	V	

RECOMMENDED OPERATING CONDITIONS

Parameter	Symbol	Min.	Typ.	Max.	Unit	Note
Case Operating Temperature	Tcase	0		+70	°C	Without air flow
Power Supply Voltage	VCC	3.14	3.3	3.47	V	
Power Supply Current	ICC	-		450	mA	
Data Rate	BR		10.3125	11.3	Gbps	
Transmission Distance	TD		-	80	km	
Coupled fiber			Single mode fiber			9/125um SMF

TELECOM/DATACOM SYSTEM

ELECTRICAL CHARACTERISTICS

Parameter	Symbol	Min	Typ	Max	Unit	Note
Supply Voltage	Vcc	3.14	3.3	3.46	V	
Supply Current	Icc			450	mA	
Transmitter						
Industrial differential impedance	ohm		100		Ω	1
Differential data input swing	V _{in} , pp	120		820	mV	
Transmit disable voltage	VD	V _{cc} -1.3		V _{cc}	V	
Transmit enable voltage	V _{en}	V _{ee}		V _{ee} +0.8	V	2
TX_FAULT Voltage-High		V _{cc} -1.3		V _{cc}	V	
TX_FAULT Voltage-Low		V _{ee}		V _{ee} +0.8	V	
Receiver						
Differential data output swing	V _{out} , pp	350		850	mV	3
LOS Fault		V _{cc} -1.3		V _{cc} Host	V	4
LOS Normal		V _{ee}		V _{cc} +0.8	V	4

Notes:

1. Connected directly to TX data input pins. AC coupled thereafter.
2. Or open circuit.
3. Into 100 ohms differential termination.
4. Loss Of Signal is LVTTTL. Logic 0 indicates normal operation; logic 1 indicates no signal detected.

OPTICAL CHARACTERISTICS

Parameter	Symbol	Min	Typ	Max	Unit	Note
Transmitter						
Average Launch Power	POUT	-1		4	dBm	1
Optical Wavelength	λ	c-0.05		c+0.05	nm	
Center Wavelength Spacing			50		GHz	2
Optical Extinction Ratio	ER	6.0			dB	
Transmitter and Dispersion Penalty	TDP			3.0	dB	
Side mode Suppression ratio	SMSR	30			dB	
Average Launch Power(Laser off)	Poff			-30	dBm	
Output Eye Mask		Compliant with IEEE 802.3ae				
Receiver						
Rx Sensitivity	RSENS			-23	dBm	3
Input Saturation Power (Overload)	Psat	-6			nm	
Wavelength Range	λ C	1480		1580	dBm	
LOS De-Assert	LOSD			-26	dBm	
LOS Assert	LOSA	-35			dB	
LOS Hysteresis		0.5				

Notes:

1. Output power is power coupled into a 9/125 mm single-mode fiber.
2. Corresponds to approximately 04 nm.
3. Measured with a PRBS 231-1 test pattern, @10.325Gb/s, BER<10⁻¹².

TELECOM/DATACOM SYSTEM

PIN DESCRIPTION

Pin	Symbol	Name /Description	NOTE
1	VEET	Transmitter Ground (Common with Receiver Ground)	1
2	T FAULT	Transmitter Fault.	2
3	T DIS	Transmitter Disable. Laser output disabled on high or open.	3
4	SDA	2-wire Serial Interface Data Line	4
5	SCL	2-wire Serial Interface Clock Line	4
6	MOD_ABS	Module Absent. Grounded within the module	4
7	RS0	Rate Select 0	5
8	LOS	Loss of Signal indication. Logic 0 indicates normal operation.	6
9	RS1	No connection required	1
10	VEER	Receiver Ground (Common with Transmitter Ground)	1
11	VEER	Receiver Ground (Common with Transmitter Ground)	1
12	RD-	Receiver Inverted DATA out. AC Coupled	
13	RD+	Receiver Non-inverted DATA out. AC Coupled	
14	VEER	Receiver Ground (Common with Transmitter Ground)	1
15	VCCR	Receiver Power Supply	
16	VCCR	Transmitter Power Supply	
17	VEER	Transmitter Ground (Common with Receiver Ground)	1
18	TD+	Transmitter Non-Inverted DATA in. AC Coupled.	
19	TD-	Transmitter Inverted DATA in. AC Coupled.	
20	VEER	Transmitter Ground (Common with Receiver Ground)	1

Notes:

- 1.Circuit ground is internally isolated from chassis ground.
- 2.TFAULT is an open collector/drain output, which should be pulled up with a 4.7k – 10k Ohms resistor on the host board if intended for use. Pull up voltage should be between 2.0V to Vcc + 0.3V.A high output indicates a transmitter fault caused by either the TX bias current or the TX output power exceeding the preset alarm thresholds. A low output indicates normal operation. In the low state, the output is pulled to <0.8V.
3. Laser output disabled on TDIS >2.0V or open, enabled on TDIS <0.8V.
4. Should be pulled up with 4.7kΩ- 10kΩ host board to a voltage between 2.0V and 3.6V. MOD_ABS pulls line low to indicate module is plugged in.
5. Internally pulled down per SFF-8431 Rev 4.1.
6. LOS is open collector output. It should be pulled up with 4.7kΩ – 10kΩ on host board to a voltage between 2.0V and 3.6V. Logic 0 indicates normal operation; logic 1 indicates loss of signal.

PIN OUT OF CONNECTOR BLACK ON HOST BOARD

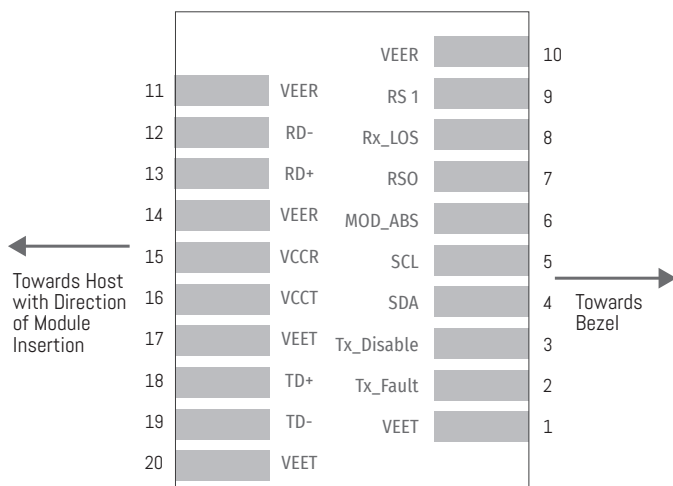

TELECOM/DATACOM SYSTEM

MECHANICAL DIMENSIONS

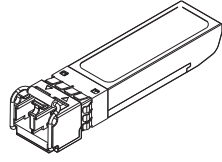
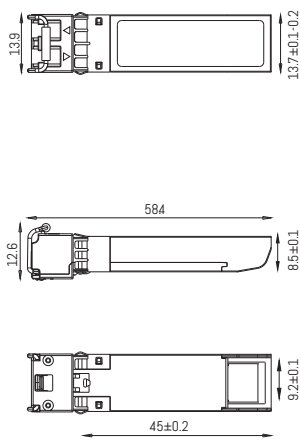

Units in mm

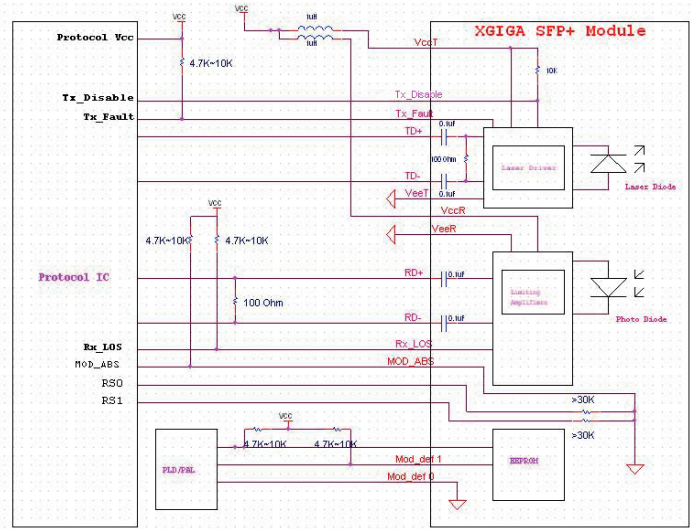

CHANNEL SELECTION

Channel	Wavelength(nm)	Frequency (THz)	Channel	Wavelength(nm)	Frequency (THz)
C17	1563.86	191.70	C39	1546.12	193.90
H17	1563.45	191.75	H39	1545.72	193.95
C18	1563.05	191.80	C40	1545.32	194.00
H18	1562.64	191.85	H40	1544.92	194.05
C19	1562.23	191.90	C41	1544.53	194.10
H19	1561.83	191.95	H41	1544.13	194.15
C20	1561.42	192.00	C42	1543.73	194.20
H20	1561.01	192.05	H42	1543.33	194.25
C21	1560.61	192.10	C43	1542.94	194.30
H21	1560.20	192.15	H43	1542.54	194.35
C22	1559.79	192.20	C44	1542.14	194.40
H22	1559.39	192.25	H44	1541.75	194.45
C23	1558.98	192.30	C45	1541.35	194.50
H23	1558.58	192.35	H45	1540.95	194.55
C24	1558.17	192.40	C46	1540.56	194.60
H24	1557.77	192.45	H46	1540.16	194.65
C25	1557.36	192.50	C47	1539.77	194.70
H25	1556.96	192.55	H47	1539.37	194.75
C26	1556.55	192.60	C48	1538.98	194.80
H26	1556.15	192.65	H48	1538.58	194.85
C27	1555.75	192.70	C49	1538.19	194.90
H27	1555.34	192.75	H49	1537.79	194.95

TELECOM/DATACOM SYSTEM

Channel	Wavelength(nm)	Frequency (THz)	Channel	Wavelength(nm)	Frequency (THz)
C28	1554.94	192.80	C50	1537.40	195.00
H28	1554.54	192.85	H50	1537.00	195.05
C29	1554.13	192.90	C51	1536.61	195.10
H29	1553.73	192.95	H51	1536.22	195.15
C30	1553.33	193.00	C52	1535.82	195.20
H30	1552.93	193.05	H52	1535.43	195.25
C31	1552.52	193.10	C53	1535.04	195.30
H31	1552.12	193.15	H53	1534.64	195.35
C32	1551.72	193.20	C54	1534.25	195.40
H32	1551.32	193.25	H54	1533.86	195.45
C33	1550.92	193.30	C55	1533.47	195.50
H33	1550.52	193.35	H55	1533.07	195.55
C34	1550.12	193.40	C56	1532.68	195.60
H34	1549.72	193.45	H56	1532.29	195.65
C35	1549.32	193.50	C57	1531.90	195.70
H35	1548.91	193.55	H57	1531.51	195.75
C36	1548.51	193.60	C58	1531.12	195.80
H36	1548.11	193.65	H58	1530.72	195.85
C37	1547.72	193.70	C59	1530.33	195.90
H37	1547.32	193.75	H59	1529.94	195.95
C38	1546.92	193.80	C60	1529.55	196.00
H38	1546.52	193.85	H60	1529.16	196.05
Non ITU	Peak wavelength between 1528.77nm-1563.86		C61	1528.77	196.10

ORDERING INFORMATION

Feature	Reference	Performance
Electrostatic discharge (ESD)	IEC/EN 61000-4-2	Compatible with standards
Electromagnetic Interference (EMI)	FCC Part 15 Class B EN 55022 Class B (CISPR 22A)	Compatible with standards
Laser Eye Safety	FDA 21CFR 1040.10, 1040.11 IEC/EN 60825-1 , 2	Class 1 laser product
Component Recognition	IEC/EN 60950 , UL	Compatible with standards
ROHS	2002/95/EC.	Compatible with standards
EMC	EN61000-3	Compatible with standards

ORDERING INFORMATION

PN	Description
LSFP+SDW050xxx80-x	Lightem 10G DWDM 50GHz SFP+ Duplex LC SM Chxx 80km
xxx-	Channel
	C17/H17-C61/H61
x-	I: optional industrial grade
e.g. LSFP+SDW050H3780-I	Lightem 10G DWDM 50GHz SFP+ Duplex LC SM ChH37 80km Industrial grade