

TELECOM/DATACOM SYSTEM

Lightem 10G SFP+ Duplex LC Transceiver 1550nm Singlemode 100km LSFP+S15100

FEATURES

- Up to 11.1Gbps Data Links
- Maximum link length of 100km on SMF
- Power dissipation < 1.8W
- 1550nm EML transmitter, APD photo-detector
- Metal enclosure, for lower EMI
- 2-wire interface with integrated Digital Diagnostic monitoring
- Hot-pluggable SFP+ footprint
- Specifications compliant with SFF 8472
- Compliant with SFP+ MSA with LC connector
- Single 3.3V power supply
- Standard Operating Range: 0°C to 70°C Operating temperature
- Optional Industrial grade: -40°C to 85°C Operating temperature



APPLICATIONS

- 10GBASE-ZR
- 10G SONET/SDH, OTU2/2e

ABSOLUTE MAXIMUM RATINGS

Parameter	Symbol	Min.	Typ.	Max.	Unit	Note
Storage Temperature	Ts	-40	-	85	°C	
Relative Humidity	RH	5	-	95	%	
Power Supply Voltage	VCC	-0.3	-	+4	V	
Signal Input Voltage		Vcc-0.3	-	Vcc+0.3	V	

RECOMMENDED OPERATING CONDITIONS

Parameter	Symbol	Min.	Typ.	Max.	Unit	Note
Case Operating Temperature	Tcase	-5		+70	°C	Commercial grade
	Tcase	-40		+85	°C	Industrial grade
Power Supply Voltage	VCC	3.14	3.3	3.47	V	
Power Supply Current	ICC	-		550	mA	
Data Rate	BR		10.3125		Gbps	
Transmission Distance	TD		-	100	km	
Coupled fiber				Single mode fiber		SMF

TELECOM/DATACOM SYSTEM

ELECTRICAL CHARACTERISTICS

Parameter	Symbol	Min	Typ	Max	Unit	Note
Supply Voltage	Vcc	3.14	3.3	3.46	V	
Supply Current	Icc			550	mA	
Transmitter						
Industrial differential impedance	RIN		100		Ω	1
Differential data input swing	Vin, pp	180		700	mV	
Transmit disable voltage	VD	Vcc-1.3		Vcc	V	
Transmit enable voltage	Ven	Vcc		Vcc+0.8	V	2
Transmit disable assert time				10	us	
Receiver						
Differential data output swing	Vout, pp	400		800	mV	3
Data output rise time	tr	30			ps	4
Data output fall time	tf	30			ps	4
LOS Fault	VLOS fault	Vcc-1.3		VccHost	V	5
LOS Normal	VLOS norm	Vcc		Vcc+0.8	V	5
Power supply rejection	PSR	100			mVpp	6

Notes:

1. Connected directly to TX data input pins. AC coupled thereafter.
2. Or open circuit.
3. Into 100 ohms differential termination.
4. 20 – 80 %.
5. Loss Of Signal is LVTTTL. Logic 0 indicates normal operation; logic 1 indicates no signal detected.

OPTICAL CHARACTERISTICS

Parameter	Symbol	Min	Typ	Max	Unit	Note
Transmitter						
Average Launch Power	POUT	1		5	dBm	1
Optical Wavelength	λ	1530	1550	1565	nm	
Optical Extinction Ratio	ER	8.2			dB	
Output Eye Mask		Compliant with IEEE 802.3aq				
Receiver						
Receiver Sensitivity	Sen			-25	dBm	2
Input Saturation Power (Overload)	Psat	-6.0			dBm	
Wavelength Range	λC	1270		1610	nm	
LOS De -Assert	LOSD			-26	dBm	
LOS Assert	LOSA	-37			dBm	
LOS Hysteresis		0.5			dB	

Notes:

1. Class 1 Laser Safety per FDA/CDRH and IEC-825-1 regulation
2. Measured with a PRBS 2³¹-1 test pattern, @ 10.3125Gb/s, BER<10⁻¹²

TELECOM/DATACOM SYSTEM

PIN DESCRIPTION

Pin	Symbol	Name /Description	NOTE
1	VEET	Transmitter Ground (Common with Receiver Ground)	1
2	T FAULT	Transmitter Fault.	2
3	T DIS	Transmitter Disable. Laser output disabled on high or open.	3
4	SDA	2-wire Serial Interface Data Line	4
5	SCL	2-wire Serial Interface Clock Line	4
6	MOD_ABS	Module Absent. Grounded within the module	4
7	RS0	Rate Select 0	5
8	LOS	Loss of Signal indication. Logic 0 indicates normal operation.	6
9	RS1	No connection required	1
10	VEER	Receiver Ground (Common with Transmitter Ground)	1
11	VEER	Receiver Ground (Common with Transmitter Ground)	1
12	RD-	Receiver Inverted DATA out. AC Coupled	
13	RD+	Receiver Non-inverted DATA out. AC Coupled	
14	VEER	Receiver Ground (Common with Transmitter Ground)	1
15	VCCR	Receiver Power Supply	
16	VCCR	Transmitter Power Supply	
17	VEER	Transmitter Ground (Common with Receiver Ground)	1
18	TD+	Transmitter Non-Inverted DATA in. AC Coupled.	
19	TD-	Transmitter Inverted DATA in. AC Coupled.	
20	VEER	Transmitter Ground (Common with Receiver Ground)	1

Notes:

- 1.Circuit ground is internally isolated from chassis ground.
- 2.TFAULT is an open collector/drain output, which should be pulled up with a 4.7k – 10k Ohms resistor on the host board if intended for use. Pull up voltage should be between 2.0V to Vcc + 0.3V.A high output indicates a transmitter fault caused by either the TX bias current or the TX output power exceeding the preset alarm thresholds. A low output indicates normal operation. In the low state, the output is pulled to <0.8V.
- 3.Laser output disabled on TDIS >2.0V or open, enabled on TDIS<0.8V.
- 4.Should be pulled up with 4.7k Ω - 10k Ω host board to a voltage between 2.0V and 3.6V. MOD_ABS pulls line low to indicate module is plugged in.
- 5.Internally pulled down per SFF-8431 Rev 4.1.
- 6.LOS is open collector output. It should be pulled up with 4.7k Ω – 10k Ω on host board to a voltage between 2.0V and 3.6V. Logic 0 indicates normal operation; logic 1 indicates loss of signal.

TELECOM/DATACOM SYSTEM

PIN OUT OF CONNECTOR BLACK ON HOST BOARD

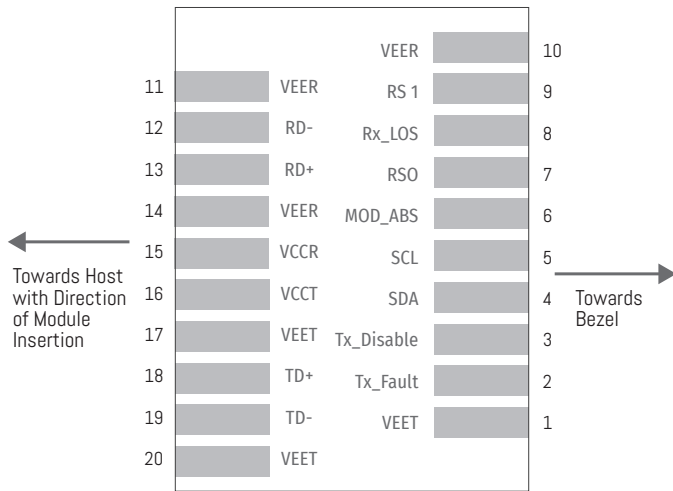

MECHANICAL DIMENSIONS

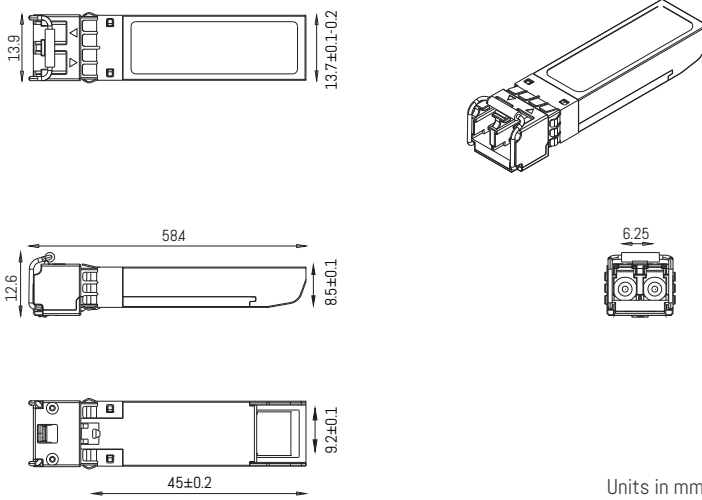

ORDERING INFORMATION

P/N	Description
LSFP+S15100-x	Lightem 10G SFP+ Duplex LC SM 1550nm 100km
x-	I: optional industrial grade
eg LSFP+S15100-I	Lightem 10G SFP+ Duplex LC SM 1550nm 100km Industrial grade