

Lightem SFP Duplex LC Transceiver LS125M85005 1.25G Multimode SX 850nm VCSEL, 0.5km

FEATURES

- Hot-pluggable SFP package
- Metal Enclosure, Excellent EMI&EMC.
- Duplex LC, Multimode SX Transceiver
- Up to 500m on 50/125um fiber (300m on 62.5/125um fiber)
- Single +3.3V Power Supply
- Standard Operating Range: 0°C to 70°C Operating temperature
- Optional Industrial grade: -40°C to 85°C Operating temperature
- 850nm VCSEL laser transmitter for SX applications
- Class 1/CDRHClass I Laser Eye Safe



APPLICATIONS

- Metro/Access Networks
- Gigabit Ethernet
- Fiber Channel
- Other Optical Link
- Compatible with HP, Extreme, Cisco, Nortel, Alcatel applications.

ABSOLUTE MAXIMUM RATINGS

Parameter	Symbol	Min.	Typ.	Max.	Unit	Note
Storage Temperature	TC	-40	-	+85	°C	
Supply Voltage	VCCT, R	-0.5	-	4	V	
Relative Humidity	RH	5	-	+85	%	

RECOMMENDED OPERATING CONDITIONS

Parameter	Symbol	Min.	Typ.	Max.	Unit	Note
Case operating Temperature	TC			70	°C	commercial grade
	TI	-40		85	°C	Industrial grade
Supply Voltage	VCCT, R	3.13	+3.3	3.47	V	
Power Supply Current	Icc		-	250	mA	commercial grade
	Icc			300	mA	Industrial grade
Data Rate (Gigabit Ethernet)			1.25		mVp-p	
Data Rate (Fiber Channel)			1.063		Gbps	
Distance on 50/125um fiber	Lmax			500	m	

TELECOM/DATACOM SYSTEM

ELECTRICAL CHARACTERISTICS

Parameter	Symbol	Min	Typ	Max	Unit	Note
Transmitter						
Input differential impedance	RIN		100		Ω	1
Single ended data input swing	Vin, pp	250		1200	mV	
TX Disable High		Vcc-1.3		Vcc	V	
TX Disable Low		Vcc		Vcc+0.8	V	
TX Fault High		Vcc-0.5		Vcc	V	
TX Fault Low		Vee		Vcc+0.5	V	
Receiver						
Single ended data out swing	Vout, pp	300	400	800	mV	2
Data output rise time	tr			175	ps	3
Data output fall time	tf			175	ps	3
LOS Fault		Vcc-0.5		Vcc	V	
LOS Low		Vcc		Vcc+0.5	V	

Notes:

1. AC coupled
2. Into 100 ohm differential termination
3. 20-80%

OPTICAL CHARACTERISTICS

Parameter	Symbol	Min	Typ	Max	Unit	Ref
Transmitter						
Output Opt. Power	PO	-9	-	-4	dBm	1
Optical Wavelength	λ	830	850	860	nm	
RMS Spectral Width	α	-	-	0.85	nm	
Optical Rise/Fall Time	tr/tf	-	-	260	ps	2
Total Jitter	TJ	-	-	0.35	UI	
Optical Extinction Ratio	ER	9	-	-	dB	
Receiver						
RX Sensitivity @ 1.25Gb/s	SENS	-	-	-18	dBm	3,4
Receiver Overload	-	0	-	-	dBm	
Optical Center Wavelength	λ_C	770	-	860	nm	
LOS De-Assert	LOSD	-	-	-19	dBm	
LOS Assert	LOSA	-40	-	-	dBm	
LOS Hysteresis	-	0.5	-	5	dB	

Notes:

1. Class 1 Laser Safety
2. Unfiltered, 20-80%. Complies with GE and 1xFC eye masks when filtered.
3. Measured with conformance signals defined in FC-PI-2Rev. 10.0 specifications
4. Measured with PRBS 2 7-1 AT 10-12 BER

TELECOM/DATACOM SYSTEM

DIGITAL DIAGNOSTIC MONITORING INTERFACE

Parameter	Range	Accuracy	Calibration
Temperature	0~+70°C (C)	±3°C	Internal
	-40~+85°C (I)		
Voltage	2.97~3.63V	±3%	Internal
Bias Current	0~100mA	±10%	Internal
TX Power	-9 ~ -4dBm	±3dB	Internal
RX Power	-18 ~ 0dBm	±3dB	Internal

PIN DESCRIPTION

Pin	Symbol	Name /Description	NOTE
1	VEER	Transmitter Ground (Common with Receiver Ground)	1
2	T FAULT	Transmitter Fault.	2
3	T DIS	Transmitter Disable. Laser output disabled on high or open.	3
4	SDA	2-wire Serial Interface Data Line	4
5	SCL	2-wire Serial Interface Clock Line	4
6	MOD_ABS	Module Absent. Grounded within the module	4
7	RS0	Rate Select 0	5
8	LOS	Loss of Signal indication. Logic 0 indicates normal operation.	6
9	RS1	No connection required	1
10	VEER	Receiver Ground (Common with Transmitter Ground)	1
11	VEER	Receiver Ground (Common with Transmitter Ground)	1
12	RD-	Receiver Inverted DATA out. AC Coupled	
13	RD+	Receiver Non-inverted DATA out. AC Coupled	
14	VEER	Receiver Ground (Common with Transmitter Ground)	1
15	VCCR	Receiver Power Supply	
16	VCCR	Transmitter Power Supply	
17	VEER	Transmitter Ground (Common with Receiver Ground)	1
18	TD+	Transmitter Non-Inverted DATA in. AC Coupled.	
19	TD-	Transmitter Inverted DATA in. AC Coupled.	
20	VEER	Transmitter Ground (Common with Receiver Ground)	1

Notes:

- Circuit ground is internally isolated from chassis ground.
- TFAULT is an open collector/drain output, which should be pulled up with a 4.7k – 10k Ohms resistor on the host board if intended for use. Pull up voltage should be between 2.0V to Vcc + 0.3VA high output indicates a transmitter fault caused by either the TX bias current or the TX output power exceeding the preset alarm thresholds. Low output indicates normal operation. In the low state, the output is pulled to <0.8V.
- Laser output disabled on TDIS >2.0V or open, enabled on TDIS<0.8V.
- Should be pulled up with 4.7kΩ- 10kΩ host board to a voltage between 2.0V and 3.6V. MOD_ABS pulls line low to indicate module is plugged in.
- Internally pulled down per SFF-8431 Rev 4.1.
- LOS is open collector output. It should be pulled up with 4.7kΩ – 10kΩ on host board to a voltage between 2.0V and 3.6V. Logic 0 indicates normal operation; logic 1 indicates loss of signal.

TELECOM/DATACOM SYSTEM

PIN OUT OF CONNECTOR BLACK ON HOST BOARD

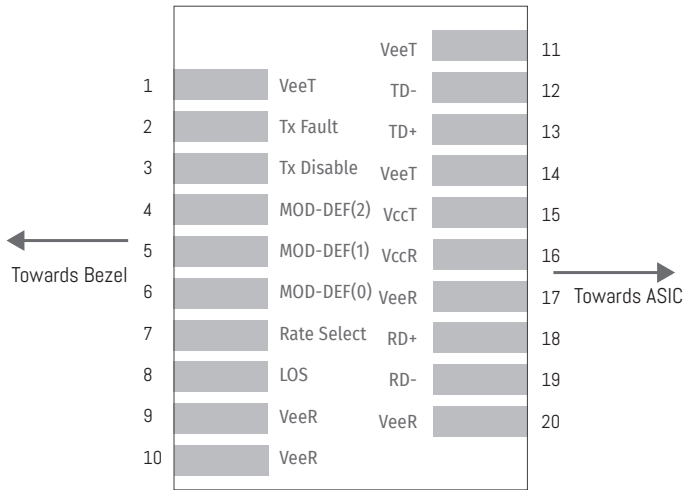

MECHANICAL DIMENSIONS

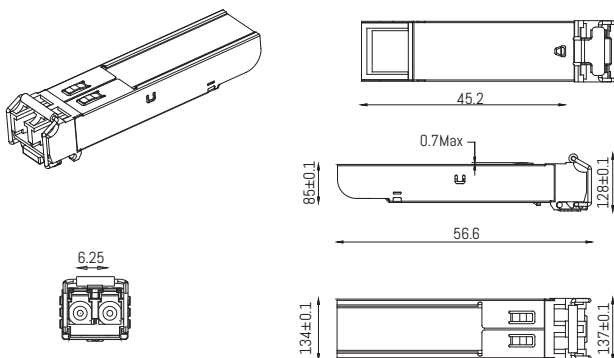

Units in mm

ORDERING INFORMATION

PN	
LS125m85005-x	Lightem 1.25G SFP Duplex LC Multimode SX 850nm 500m
x-	l: optional industrial grade
eg LS125M85005l	Lightem 1.25G SFP Duplex LC Multimode SX 850nm 500m Industrial grade