

Lightem 40Gb/s QSFP+ Singlemode Transceiver 30km Duplex LC LQSFP+S4C30-LR

FEATURES

- 4Ch CWDM Mux /Demux Design
- High Channel Capacity: 40 Gbps per module
- Up to 11.1Gbps Data rate per channel
- Up to 30km on SMF
- Electrically hot-pluggable
- Compliant with QSFP+ MSA with LC connector
- Case operating temperature range:0°C to 70°C
- Power dissipation < 3.5 W



APPLICATIONS

- 40G Ethernet
- Data Center and LAN

ABSOLUTE MAXIMUM RATINGS

Parameter	Symbol	Min.	Typ.	Max.	Unit	Note
Storage Temperature	Ts	-40	-	85	°C	
Relative Humidity	RH	5	-	95	%	
Power Supply Voltage	VCC	-0.3	-	+4	V	
Signal Input Voltage		Vcc-0.3	-	Vcc+0.3	V	
Damage Threshold		3.4	-		dBm	

RECOMMENDED OPERATING CONDITIONS

Parameter	Symbol	Min.	Typ.	Max.	Unit	Note
Case Operating Temperature	Tcase	0	-	+70	°C	Commercial grade
	Tcase	-40	-	+85	°C	Industrial grade
Power Supply Voltage	VCC	3.14	3.3	3.46	V	
Power Supply Current	ICC	-	-	1060	mA	
Data Rate	BR		10.3125		Gbps	Each channel
Transmission Distance	TD		-	30	km	SMF

TELECOM/DATACOM SYSTEM

ELECTRICAL CHARACTERISTICS

Parameter	Symbol	Min	Typ	Max	Unit	Note
Supply Voltage	Vcc2	3.14	3.3	3.46	V	
Supply Current	Icc			1060	mA	
Transmitter						
Input differential impedance	RIN		100		Ω	1
Differential data input swing	Vin, pp	180		1000	mV	
Single ended input voltage tolerance	Vin T	-0.3		4	V	
Receiver						
Differential data output swing	Vout, pp	300		850	mV	2
Single ended output voltage		-0.03		4	V	

Notes:

- 1.Connected directly to TX data input pins. AC coupled thereafter
- 2.Into 100 ohms differential termination

OPTICAL CHARACTERISTICS

Parameter	Symbol	Min	Typ	Max	Unit	Note
Transmitter						
Wavelength Assignment	$\lambda 0$	1264.5	1271	1277.5	nm	
	$\lambda 1$	1284.5	1291	1297.5		
	$\lambda 2$	1304.5	1311	1317.5		
	$\lambda 3$	1324.5	1331	1337.5		
Total Output Power	Pout			8.3	dBm	
Average Launch Power each lane		-2		2.3	dBm	
Spectral Width (-20dB)	σ			1	nm	
Optical Extinction Ratio	ER	3.5			dB	
Average launch Power off each lane	Poff			-30	dBm	
Output Eye Mask	TDP	Compliant with IEEE 802.3ba				
Receiver						
Rx Sensitivity per lane	RSNS			-12	dBm	
Input Saturation Power (Overload)	Psat	2.3			dBm	1
Receiver Reflectance	Rr			-26	dB	

Notes:

- 1.Measured with a PRBS 231-1 test pattern, @10.325Gb/s, BER<10-12

TELECOM/DATACOM SYSTEM

PIN DESCRIPTION

Pin	Symbol	Name /Description	1
1	GND	Transmitter Ground (Common with Receiver Ground)	
2	Tx2n	Transmitter Inverted Data Input	
3	Tx2p	Transmitter Non-Inverted Data output	1
4	GND	Transmitter Ground (Common with Receiver Ground)	
5	Tx4n	Transmitter Inverted Data Input	
6	Tx4p	Transmitter Non-Inverted Data output	1
7	GND	Transmitter Ground (Common with Receiver Ground)	
8	ModSell	Module Select	
9	ResetL	Module Reset	2
10	VccRx	3.3V Power Supply Receiver	
11	SCL	2-Wire serial Interface Clock	
12	SDA	2-Wire serial Interface Data	
13	GND	Transmitter Ground (Common with Receiver Ground)	
14	Rx3p	Receiver Non-Inverted Data Output	
15	Rx3n	Receiver Inverted Data Output	1
16	GND	Transmitter Ground (Common with Receiver Ground)	
17	Rx1p	Receiver Non-Inverted Data Output	
18	Rx1n	Receiver Inverted Data Output	1
19	GND	Transmitter Ground (Common with Receiver Ground)	1
20	GND	Transmitter Ground (Common with Receiver Ground)	
21	Rx2n	Receiver Inverted Data Output	
22	Rx2p	Receiver Non-Inverted Data Output	1
23	GND	Transmitter Ground (Common with Receiver Ground)	1
24	Rx4n	Receiver Inverted Data Output	
25	Rx4p	Receiver Non-Inverted Data Output	1
26	GND	Transmitter Ground (Common with Receiver Ground)	
27	ModPrsl	Module Present	
28	IntL	Interrupt	2
29	VccTx	3.3V power supply transmitter	2
30	Vcc1	3.3V power supply	
31	LPMODE	Low Power Mode , not connect	1
32	GND	Transmitter Ground (Common with Receiver Ground)	
33	Tx3p	Transmitter Non-Inverted Data Input	
34	Tx3n	Transmitter Inverted Data Output	1
35	GND	Transmitter Ground (Common with Receiver Ground)	
36	Tx1p	Transmitter Non-Inverted Data Input	
37	Tx1n	Transmitter Inverted Data Output	1
38	GND	Transmitter Ground (Common with Receiver Ground)	

Notes:

1.GND is the symbol for signal and supply(power) common for QSFP+ modules. All are common within the QSFP+ module and all module voltages are referenced to this potential unless otherwise noted. Connect these directly to the host board signal common ground plane.

2.VccRx, Vcc1 and VccTx are the receiving and transmission power suppliers and shall be applied concurrently. Recommended host board power supply filtering is shown below. Vcc Rx, Vcc1 and Vcc Tx may be internally connected within the QSFP+ transceiver module in any combination. The connector pins are each rated for a maximum current of 500mA.

TELECOM/DATACOM SYSTEM

PIN OUT OF CONNECTOR BLACK ON HOST BOARD

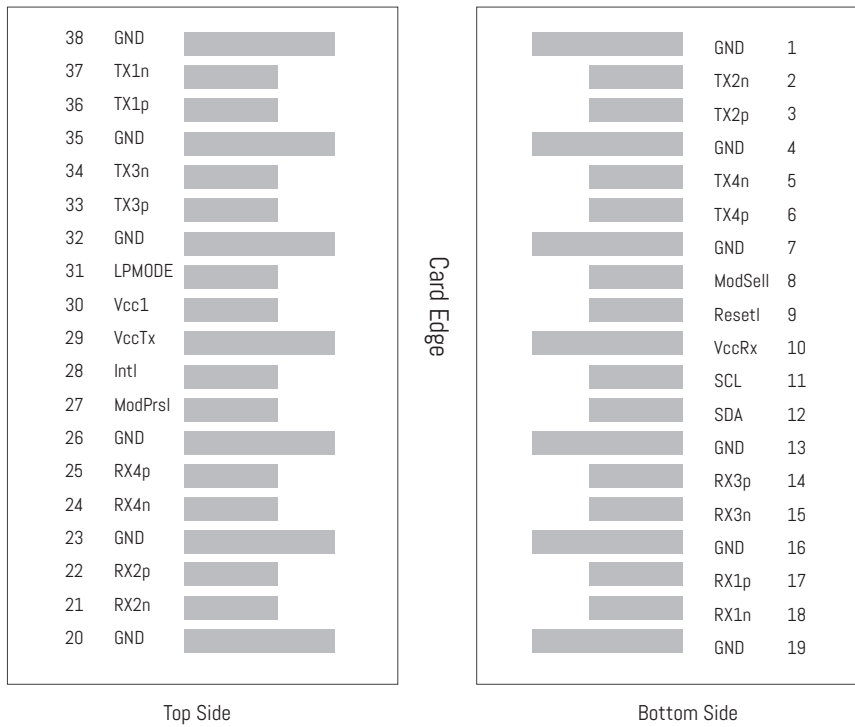

MECHANICAL DIMENSIONS

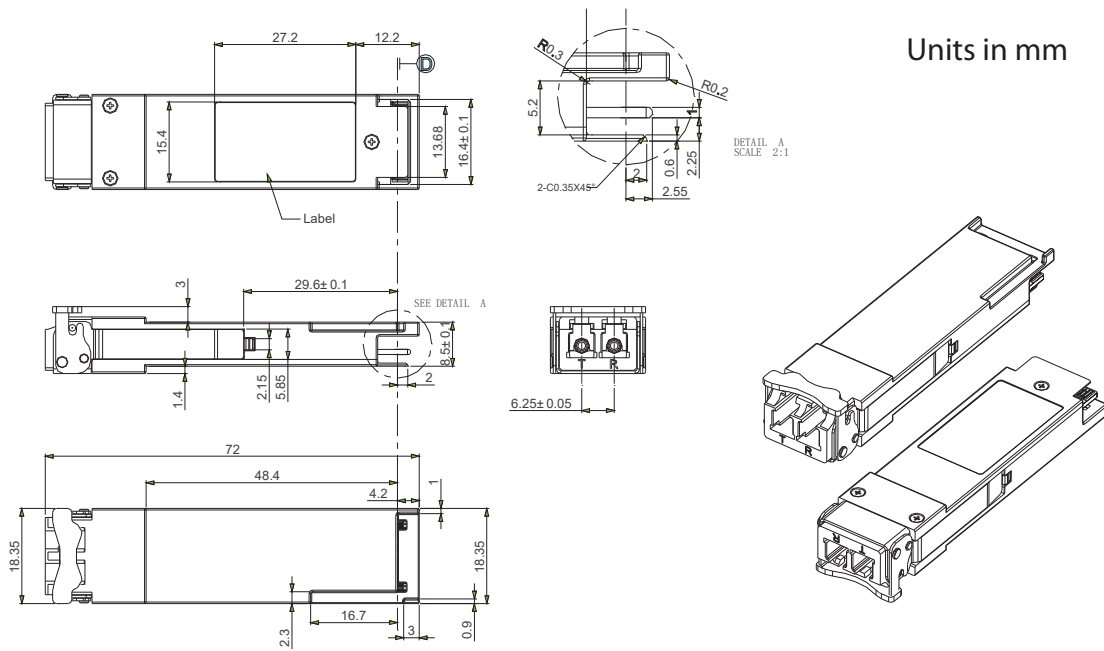

ORDERING INFORMATION

PN	Description
LQSFP+S4C30-LR	Lightem 40Gb/s QSFP+ Singlemode Transceiver 30km Duplex LC