

Lightem 100Gb/s QSFP28 CWDM4 Singlemode Transceiver 2km Duplex LC LQSFP28S4C02

FEATURES

- 4 CWDM lanes Mux/De-mux design
- Up to 2km links on Singlemode fiber
- Up to 27.952Gbps Data rate per channel
- Electrically hot-pluggable
- Compliant with QSFP28 MSA
- Case operating temperature range:0°C to 70°C
- Power dissipation < 3.5W



APPLICATIONS

- 100G Ethernet
- Data center and LAN

ABSOLUTE MAXIMUM RATINGS

Parameter	Symbol	Min.	Typ.	Max.	Unit	Note
Storage Temperature	Ts	-40	-	85	°C	
Relative Humidity	RH	5	-	95	%	
Power Supply Voltage	VCC	-0.3	-	4	V	
Signal Input Voltage		Vcc-0.3	-	Vcc+0.3	V	

RECOMMENDED OPERATING CONDITIONS

Parameter	Symbol	Min.	Typ.	Max.	Unit	Note
Case Operating Temperature	Tcase	0		+70	°C	Commercial grade
Power Supply Voltage	VCC	3.14	3.3	3.46	V	
Power Supply Current	ICC	-		900	mA	
Data Rate	BR		25.78125		Gbps	Each Channel
Transmission Distance	TD		-	2	Km	MMF

ELECTRICAL CHARACTERISTICS

Parameter	Symbol	Min	Typ	Max	Unit	Note
Supply Voltage	Vcc	3.14	3.3	3.46	V	
Supply Current	I _{cc}			900	mA	
Transmitter						
Industrial differential impedance	RIN		100		Ω	1
Differential data input swing	V _{in, pp}	180		1000	mV	
Single ended input voltage tolerance	V _{inT}	-0.3		4	V	
Receiver						
Differential data out swing	V _{out, pp}	300		850	mV	2

Notes:

- 1.Connected directly to TX data input pins. AC coupled thereafter
- 2.Into 100 ohms differential termination

TELECOM/DATACOM SYSTEM

OPTICAL CHARACTERISTICS

Parameter	Symbol	Min	Typ	Max	Unit	Note
Transmitter						
Wavelength Assignment	λ_0	1264.5	1271	1277.5	nm	
	λ_1	1284.5	1291	1297.5		
	λ_2	1304.5	1311	1317.5		
	λ_3	1324.5	1331	1337.5		
Total Output Power	Pout			8.5	dBm	
Average Launch Power each lane		-6.5		2.5	dBm	
Spectral Width (-20dB)	σ			1	nm	
Optical Extinction Ratio	ER	3.5			dB	
Average launch Power off each lane	Poff			-30	dBm	
Output Eye Mask (X1,X2,X3,Y1,Y2,Y3)		(0.25, 0.42, 0.46, 0.28, 0.3, 0.4)				
Receiver						
Rx Sensitivity per lane	RSENS			-10	dBm	
Input Saturation Power (Overload)	Psat			2.5	dBm	1
Receiver Reflectance	Rr			-26	dB	

Notes:

1. Measured with a PRBS 231-1 test pattern, @10.325Gb/s, BER<10⁻¹²

PIN DESCRIPTION

Pin	Symbol	Symbol	NOTE
38	GND	GND	1
37	TX1n	TX2n	2
36	TX1p	TX2p	3
35	GND	GND	4
34	TX3n	TX4n	5
33	TX3p	TX4p	6
32	GND	GND	7
31	LPMODE	ModSelL	8
30	Vcc1	ResetL	9
29	VccTx	VccRx	10
28	IntL	SCL	11
27	ModPrsl	SDA	12
26	GND	GND	13
25	RX4p	RX3p	14
24	RX4n	RX3n	15
23	GND	GND	16
22	RX4p	RX1p	17
21	RX4n	RX1n	18
20	GND	GND	19

TELECOM/DATACOM SYSTEM

Pin	Symbol	Name/Description	NOTE
1	GND	Transmitter Ground (Common with Receiver Ground)	1
2	Tx2n	Transmitter Inverted Data Input	
3	Tx2p	Transmitter Non-Inverted Data output	
4	GND	Transmitter Ground (Common with Receiver Ground)	1
5	Tx4n	Transmitter Inverted Data Input	
6	Tx4p	Transmitter Non-Inverted Data output	
7	GND	Transmitter Ground (Common with Receiver Ground)	1
8	ModSelL	Module Select	
9	ResetL	Module Reset	
10	VccRx	3.3V Power Supply Receiver	2
11	SCL	2-Wire serial Interface Clock	
12	SDA	2-Wire serial Interface Data	
13	GND	Transmitter Ground (Common with Receiver Ground)	
14	Rx3p	Receiver Non-Inverted Data Output	
15	Rx3n	Receiver Inverted Data Output	
16	GND	Transmitter Ground (Common with Receiver Ground)	1
17	Rx1p	Receiver Non-Inverted Data Output	
18	Rx1n	Receiver Inverted Data Output	
19	GND	Transmitter Ground (Common with Receiver Ground)	1
20	GND	Transmitter Ground (Common with Receiver Ground)	1
21	Rx2n	Receiver Inverted Data Output	
22	Rx2p	Receiver Non-Inverted Data Output	
23	GND	Transmitter Ground (Common with Receiver Ground)	1
24	Rx4n	Receiver Inverted Data Output	1
25	Rx4p	Receiver Non-Inverted Data Output	
26	GND	Transmitter Ground (Common with Receiver Ground)	1
27	ModPrsl	Module Present	
28	IntL	Interrupt	
29	VccTx	3.3V power supply transmitter	2
30	Vcc1	3.3V power supply	2
31	LPMODE	Low Power Mode , not connect	
32	GND	Transmitter Ground (Common with Receiver Ground)	1
33	Tx3p	Transmitter Non-Inverted Data Input	
34	Tx3n	Transmitter Inverted Data Output	
35	GND	Transmitter Ground (Common with Receiver Ground)	1
36	Tx1p	Transmitter Non-Inverted Data Input	
37	Tx1n	Transmitter Inverted Data Output	
38	GND	Transmitter Ground (Common with Receiver Ground)	1

Notes:

1. GND is the symbol for signal and supply(power) common for QSFP+ modules. All are common within the QSFP+ module and all module voltages are referenced to this potential unless otherwise noted. Connect these directly to the host board signal common ground plane.
2. VccRx, Vcc1 and VccTx are the receiving and transmission power suppliers and shall be applied concurrently. Recommended host board power supply filtering is shown below. Vcc Rx, Vcc1 and Vcc Tx may be internally connected within the QSFP+ transceiver module in any combination. The connector pins are each rated for a maximum current of 500mA.

TELECOM/DATACOM SYSTEM

MECHANICAL DIMENSIONS

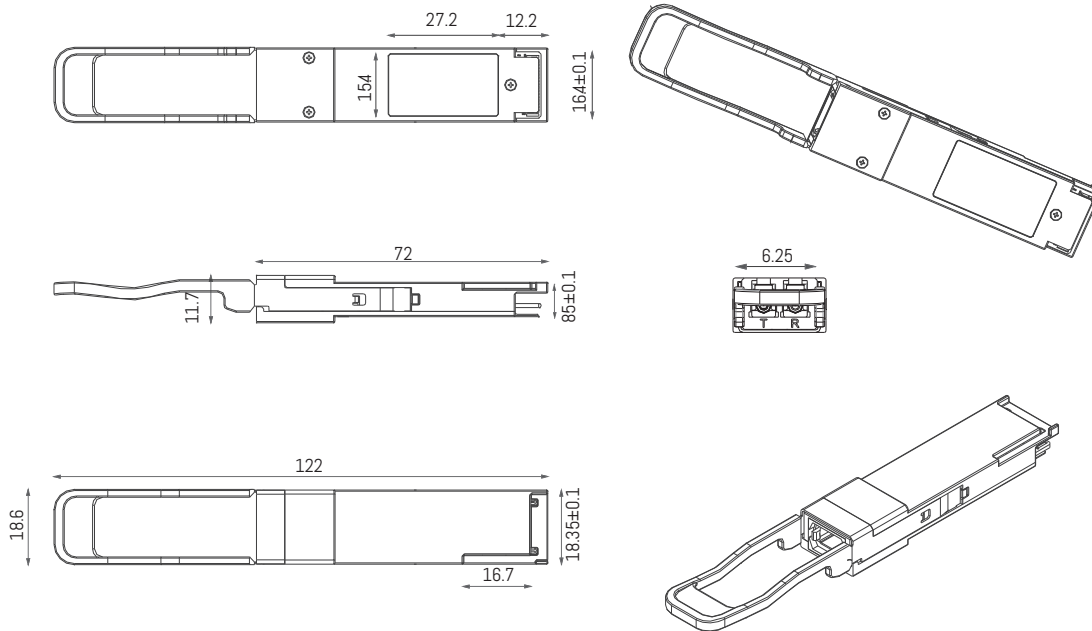

ORDERING INFORMATION

PN	Description
LQSFP28S4C02	100Gb/s QSFP28 CWDM4 Singlemode Transceiver 2km Duplex LC