

Lightem 1.25Gbps Bi-Directional SFP Transceiver Simplex LC 40km LB125S35400 - Tx/Rx: 1310/1550nm

FEATURES

- Standard SFP package.
- Metal Enclosure, Excellent EMI&EMC.
- Simplex LC, Single-Mode Transceiver 40km, Tx/Rx: 1310/1550nm
- Single +3.3V Power Supply
- Standard Operating Range: 0°C to 70°C Operating temperature
- Optional Industrial grade: -40°C to 85°C Operating temperature
- 1310nm FP laser transmitter for LH applications
- Class 1/CDRHClass I Laser Eye Safe
- RoHS Compliant Products Available



APPLICATIONS

- Metro/Access Networks
- Gigabit Ethernet
- Fiber Channel
- Other Optical Link
- Compatible with HP, Extreme, Cisco, Nortel, Alcatel applications.

ABSOLUTE MAXIMUM RATINGS

Parameter	Symbol	Min.	Typ.	Max.	Unit	Note
Storage Temperature	TC	-40	-	+85	°C	
Supply Voltage	VCCT, R	-0.5	-	4	V	
Relative Humidity	RH	5	-	+95	%	

RECOMMENDED OPERATING CONDITIONS

Parameter	Symbol	Min.	Typ.	Max.	Unit
Case operating Temperature	TC	-40		+70 (Commercial)	°C
	TI	3.13		+85 (Industrial)	°C
Supply Voltage	VCCT, R		+3.3	3.47	V
Power Supply Current	Icc		-	250 (Commercial)	mA
	Icc			300 (Industrial)	mA
Data Rate (Gigabit Ethernet)			1.25		Gbps
Data Rate (Fiber Channel)			1.063		Gbps
Distance on 9/125um G.652 SMF	Lmax			40	km

TELECOM/DATACOM SYSTEM

ELECTRICAL CHARACTERISTICS (TOP = 25°C, VCC = 3.3 VOLTS)

Parameter	Symbol	Min	Typ	Max	Unit	Note
Transmitter						
Input differential impedance	RIN		100		Ω	1
Single ended data input swing	V _{in} , pp	250		1200	mV	
TX Disable High		V _{cc} -1.3		V _{cc}	V	
TX Disable Low		V _{cc}		V _{cc} +0.8	V	
TX Fault High		V _{cc} -0.5		V _{cc}	V	
TX Fault Low		V _{ee}		V _{cc} +0.5	V	
Receiver						
Single ended data out swing	V _{out} , pp	300	400	800	mV	2
Data output rise time	t _r			300	ps	3
Data output fall time	t _f			300	ps	3
LOS Fault		V _{cc} -0.5		V _{cc}	V	
LOS Low		V _{cc}		V _{cc} +0.5	V	

OPTICAL CHARACTERISTICS

Tx/Rx: 1310/1550nm	Symbol	Min	Typ	Max	Unit	Ref
Transmitter						
Output Optical Power	POUT	-5	-	0	dBm	1
Optical Wavelength	λ	1275	1310	1350	nm	
RMS Spectral Width	Δλ	-	-	3	nm	
Optical Rise/Fall Time	t _r / t _f	-	-	260	ps	2
Total Jitter	TJ	-	-	0.35	UI	
Optical Extinction Ratio	ER	9	-	-	dB	
Receiver						
Rx Sensitivity @ 1.25Gb/s	SENS	-	-	-25	dBm	3,4
Receiver Overload	-	0	-	-	dBm	
Optical Center Wavelength	λ _c	1530	-	1570	nm	
LOS De-Assert	LOSD	-	-	-26	dBm	
LOS Assert	LOSA	-40	-	-	dBm	
LOS Hysteresis	-	0.5	-	5	dB	

Notes:

1. Class 1 laser safety
2. Unfiltered, 20-80%. Complies with Gigabit Ethernet eye masks when filtered
3. Measured with conformance signals defined in FC PI-2 Rev. 10.0 specification
4. Measured with PRBS 27 -1 at 10-12 BER

TELECOM/DATACOM SYSTEM

DIGITAL DIAGNOSTIC MONITORING INTERFACE

Parameter	Range	Accuracy	Calibration
Temperature	0~+70°C (C)	±3°C	Internal
	-40~+85°C (I)		
Voltage	2.97 3.63V	±3%	Internal
Bias Current	0~100mA	±10%	Internal
TX Power	-5-0dBm	±3dB	Internal
RX Power	-25-0dBm	±3dB	Internal

PIN DESCRIPTION

Pin	Symbol	Name /Description	NOTE
1	VEER	Transmitter Ground (Common with Receiver Ground)	1
2	T FAULT	Transmitter Fault.	2
3	T DIS	Transmitter Disable. Laser output disabled on high or open.	3
4	SDA	2-wire Serial Interface Data Line	4
5	SCL	2-wire Serial Interface Clock Line	4
6	MOD_ABS	Module Absent. Grounded within the module	4
7	RS0	Rate Select 0	5
8	LOS	Loss of Signal indication. Logic 0 indicates normal operation.	6
9	RS1	No connection required	1
10	VEER	Receiver Ground (Common with Transmitter Ground)	1
11	VEER	Receiver Ground (Common with Transmitter Ground)	1
12	RD-	Receiver Inverted DATA out. AC Coupled	
13	RD+	Receiver Non-inverted DATA out. AC Coupled	
14	VEER	Receiver Ground (Common with Transmitter Ground)	1
15	VCCR	Receiver Power Supply	
16	VCCR	Transmitter Power Supply	
17	VEER	Transmitter Ground (Common with Receiver Ground)	1
18	TD+	Transmitter Non-Inverted DATA in. AC Coupled.	
19	TD-	Transmitter Inverted DATA in. AC Coupled.	
20	VEER	Transmitter Ground (Common with Receiver Ground)	1

Notes:

1. Circuit ground is internally isolated from chassis ground.
2. TFAULT is an open collector/drain output, which should be pulled up with a 4.7k – 10k Ohms resistor on the host board if intended for use. Pull up voltage should be between 2.0V to Vcc + 0.3VA high output indicates a transmitter fault caused by either the TX bias current or the TX output power exceeding the preset alarm thresholds. Low output indicates normal operation. In the low state, the output is pulled to <0.8V.
3. Laser output disabled on TDIS >2.0V or open, enabled on TDIS<0.8V.
4. Should be pulled up with 4.7kΩ- 10kΩ host board to a voltage between 2.0V and 3.6V. MOD_ABS pulls line low to indicate module is plugged in.
5. Internally pulled down per SFF-8431 Rev 4.1.
6. LOS is open collector output. It should be pulled up with 4.7kΩ – 10kΩ on host board to a voltage between 2.0V and 3.6V. Logic 0 indicates normal operation; logic 1 indicates loss of signal.

TELECOM/DATACOM SYSTEM

PIN OUT OF CONNECTOR BLACK ON HOST BOARD

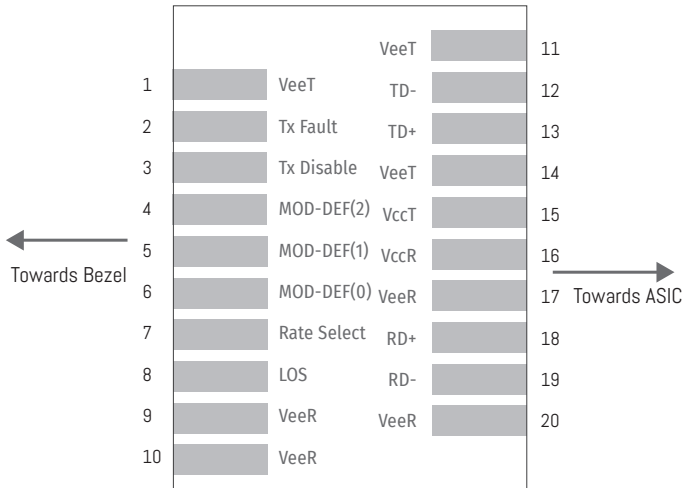

MECHANICAL DIMENSIONS

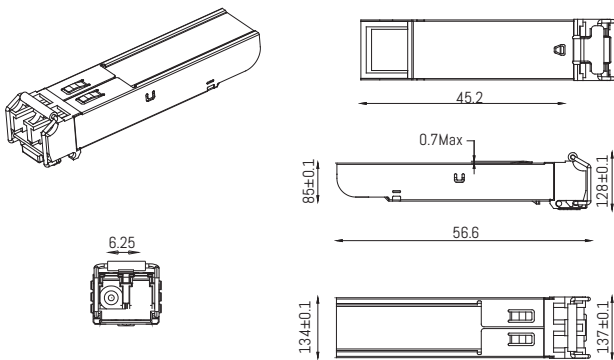

Units in mm

ORDERING INFORMATION

PN	
LB125S35400-x	1.25Gbps Bi-Directional SFP Transceiver Simplex LC 40km Tx/Rx: 1310/1550nm
x-	l: optional industrial grade
eg LB125S35400l	1.25G Bi-Directional SFP Transceiver Simplex LC 40km Tx/Rx: 1310/1550nm Industrial grade